

# Family Emergency Preparedness Handbook



**Helaman 5:12 And now, my sons, remember, remember that it is upon the rock of our Redeemer, who is Christ, the Son of God, that ye must build your foundation; that when the devil shall send forth his mighty winds, yea, his shafts in the whirlwind, yea, when all his hail and his mighty storm shall beat upon you, it shall have no power over you to drag you down to the gulf of misery and endless wo, because of the rock upon which ye are built, which is a sure foundation, a foundation wherein if men build they cannot fall.**

# Family Emergency Preparedness Handbook

November 2005

Before an emergency happens.....

## PLAN.....PREPARE.....BE INFORMED

This manual will help you and your family **PLAN** for an emergency, **PREPARE** your home, supplies and equipment for an emergency, and **BE INFORMED** on what to do for the most likely emergencies to occur in our area. It will also provide essential information to neighbors or emergency personnel who may be trying to help your family.

### COMPLETE YOUR HANDBOOK:

- Designate a regular place for your manual that is easily accessible for your family and others who will need access to the information it contains. **(Above the refrigerator?)**
- When placing the photographs in the information section, please note the age /date of the photograph (periodically insert a more current photo.)
- Write in pencil so you can make changes later.
- In the contact section, designate an out of state relative as the disaster contact. Inform all family members that everyone needs to check in with them and be sure everyone has their telephone number memorized and/or in their wallet to be able to make contact.
- Make a sketch of the floor plan of your home. Show the location of where to shut off all utilities. Note the locations of your essential supplies and equipment for an emergency, so others could help you get what you need.

### SOURCES OF INFORMATION

Federal Emergency Management Agency (FEMA)  
Utah Department of Homeland Security  
[www.lds.org](http://www.lds.org)

Utah Department of Emergency Services  
American Red Cross

# Table of Contents

## **PLAN**

Family Checklist . . . . .	4
Family Member Info . . . . .	5
Home Teaching/Visiting Teaching Information Sheet. . . . .	7
House plan . . . . .	8
Evacuation Plan . . . . .	9
Utility Shut Off . . . . .	10

## **PREPARE**

Water Storage . . . . .	11
Food Storage . . . . .	12
72 Hour Kit . . . . .	13
Infants, Children, Senior Citizens, Pets Kits . . . . .	14
Important Non Food Items . . . . .	15
Alternative Heat, Light and Power . . . . .	16
Other Emergency Kits . . . . .	17
First Aid Supplies . . . . .	18
First Aid Basics . . . . .	19
Sanitation . . . . .	20
Communications/Essential Documents . . . . .	21
Make your home Safer for Earthquakes . . . . .	22

## **BE INFORMED**

Emergency Basics . . . . .	25
In Case of Earthquake . . . . .	26
Power Outage, High Winds . . . . .	27
Severe Thunder & Lightning . . . . .	27
Blizzards, Floods . . . . .	28
Fires . . . . .	28
Chemical Spills, Shelter In Place . . . . .	29
Other Sources of Information (Websites) . . . . .	30
Notification of Emergency Services/Ward/Stake Members. . . . .	31

# Family Preparedness Checklist

Meet with your family today and discuss why you need a preparedness plan. Explain the dangers of fire, flood, wind, earthquakes and chemical spill to children. Use this checklist to prepare your family.

Task	Start Action Date	End Action Date
1. Complete the Family Information forms in this book.		
2. Make your house plan - mark the location of utilities and emergency supplies.		
3. Plan for an evacuation - list the most important items to take with you		
4. Teach older children how and when to turn off all utilities		
5. Evaluate your home security and plan how to improve it.		
6. Check and rotate emergency water supplies.		
7. Be able to purify unsafe water.		
8. Take inventory of your food storage and make a plan to increase it.		
9. Check and rotate your 72 hour "Go Kit". Store where it is easily accessible.		
10. Check and rotate items in your First Aid Kit.		
11. Take a First Aid Class: Learn CPR. Take a CERT class.		
12. Make plans for emergency cooking, heating, and lighting.		
13. Prepare a sanitation kit.		
14. Check and recharge fire extinguishers if necessary.		
15. Check and replace smoke and Carbon Monoxide detectors.		
16. Bolt down water heaters, tall shelves and appliances before the earthquake.		
17. Prepare financially by staying out of debt and saving for the future.		
18. Replace batteries in emergency radios and lights.		
19. Review your Emergency Plan with your family!		

**FAMILY MEMBER**

Name \_\_\_\_\_

Age \_\_\_\_\_

Birth date \_\_\_\_\_

Gender \_\_\_\_\_

Height \_\_\_\_\_

Weight \_\_\_\_\_

Hair color \_\_\_\_\_

Eye color \_\_\_\_\_

School/Employer \_\_\_\_\_

\_\_\_\_\_

\_\_\_\_\_

Phone \_\_\_\_\_

Physician \_\_\_\_\_

\_\_\_\_\_

Phone \_\_\_\_\_

Allergies/Medical

Condition \_\_\_\_\_

\_\_\_\_\_

\_\_\_\_\_

Medications \_\_\_\_\_

\_\_\_\_\_

\_\_\_\_\_

Name \_\_\_\_\_

Age \_\_\_\_\_

Birth date \_\_\_\_\_

Gender \_\_\_\_\_

Height \_\_\_\_\_

Weight \_\_\_\_\_

Hair color \_\_\_\_\_

Eye color \_\_\_\_\_

School/Employer \_\_\_\_\_

\_\_\_\_\_

\_\_\_\_\_

Phone \_\_\_\_\_

Physician \_\_\_\_\_

\_\_\_\_\_

Phone \_\_\_\_\_

Allergies/Medical

Condition \_\_\_\_\_

\_\_\_\_\_

\_\_\_\_\_

Medications \_\_\_\_\_

\_\_\_\_\_

\_\_\_\_\_

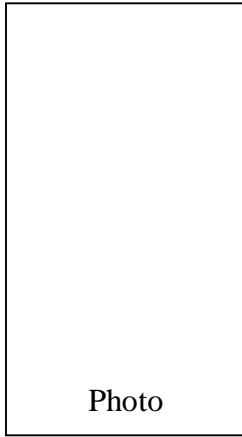

Photo

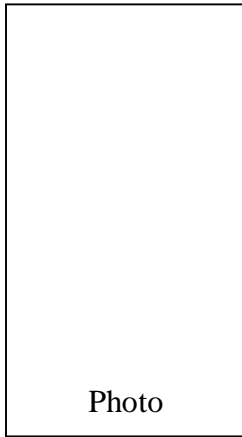

Photo

**INFORMATION**

Name \_\_\_\_\_

Age \_\_\_\_\_

Birth date \_\_\_\_\_

Gender \_\_\_\_\_

Height \_\_\_\_\_

Weight \_\_\_\_\_

Hair color \_\_\_\_\_

Eye color \_\_\_\_\_

School/Employer \_\_\_\_\_

\_\_\_\_\_

\_\_\_\_\_

Phone \_\_\_\_\_

Physician \_\_\_\_\_

\_\_\_\_\_

Phone \_\_\_\_\_

Allergies/Medical

Condition \_\_\_\_\_

\_\_\_\_\_

\_\_\_\_\_

Medications \_\_\_\_\_

\_\_\_\_\_

\_\_\_\_\_

Name \_\_\_\_\_

Age \_\_\_\_\_

Birth date \_\_\_\_\_

Gender \_\_\_\_\_

Height \_\_\_\_\_

Weight \_\_\_\_\_

Hair color \_\_\_\_\_

Eye color \_\_\_\_\_

School/Employer \_\_\_\_\_

\_\_\_\_\_

\_\_\_\_\_

Phone \_\_\_\_\_

Physician \_\_\_\_\_

\_\_\_\_\_

Phone \_\_\_\_\_

Allergies/Medical

Condition \_\_\_\_\_

\_\_\_\_\_

\_\_\_\_\_

Medications \_\_\_\_\_

\_\_\_\_\_

\_\_\_\_\_

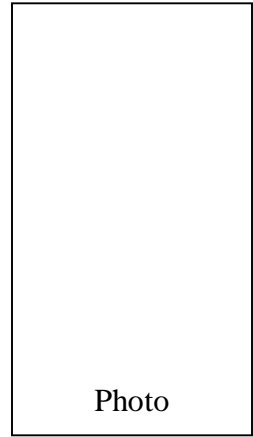

Photo

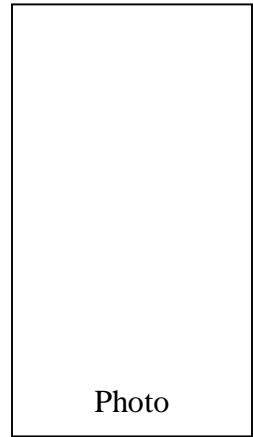

Photo

**FAMILY MEMBER**

Name \_\_\_\_\_

Age \_\_\_\_\_

Birth date \_\_\_\_\_

Gender \_\_\_\_\_

Height \_\_\_\_\_

Weight \_\_\_\_\_

Hair color \_\_\_\_\_

Eye color \_\_\_\_\_

School/Employer \_\_\_\_\_

\_\_\_\_\_

\_\_\_\_\_

Phone \_\_\_\_\_

Physician \_\_\_\_\_

\_\_\_\_\_

Phone \_\_\_\_\_

Allergies/Medical Condition \_\_\_\_\_

\_\_\_\_\_

\_\_\_\_\_

Medications \_\_\_\_\_

\_\_\_\_\_

\_\_\_\_\_

Name \_\_\_\_\_

Age \_\_\_\_\_

Birth date \_\_\_\_\_

Gender \_\_\_\_\_

Height \_\_\_\_\_

Weight \_\_\_\_\_

Hair color \_\_\_\_\_

Eye color \_\_\_\_\_

School/Employer \_\_\_\_\_

\_\_\_\_\_

\_\_\_\_\_

Phone \_\_\_\_\_

Physician \_\_\_\_\_

\_\_\_\_\_

Phone \_\_\_\_\_

Allergies/Medical Condition \_\_\_\_\_

\_\_\_\_\_

\_\_\_\_\_

Medications \_\_\_\_\_

\_\_\_\_\_

\_\_\_\_\_

**INFORMATION**

Name \_\_\_\_\_

Age \_\_\_\_\_

Birth date \_\_\_\_\_

Gender \_\_\_\_\_

Height \_\_\_\_\_

Weight \_\_\_\_\_

Hair color \_\_\_\_\_

Eye color \_\_\_\_\_

School/Employer \_\_\_\_\_

\_\_\_\_\_

\_\_\_\_\_

Phone \_\_\_\_\_

Physician \_\_\_\_\_

\_\_\_\_\_

Phone \_\_\_\_\_

Allergies/Medical Condition \_\_\_\_\_

\_\_\_\_\_

\_\_\_\_\_

Medications \_\_\_\_\_

\_\_\_\_\_

\_\_\_\_\_

Name \_\_\_\_\_

Age \_\_\_\_\_

Birth date \_\_\_\_\_

Gender \_\_\_\_\_

Height \_\_\_\_\_

Weight \_\_\_\_\_

Hair color \_\_\_\_\_

Eye color \_\_\_\_\_

School/Employer \_\_\_\_\_

\_\_\_\_\_

\_\_\_\_\_

Phone \_\_\_\_\_

Physician \_\_\_\_\_

\_\_\_\_\_

Phone \_\_\_\_\_

Allergies/Medical Condition \_\_\_\_\_

\_\_\_\_\_

\_\_\_\_\_

Medications \_\_\_\_\_

\_\_\_\_\_

\_\_\_\_\_

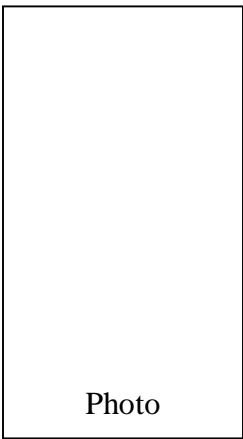
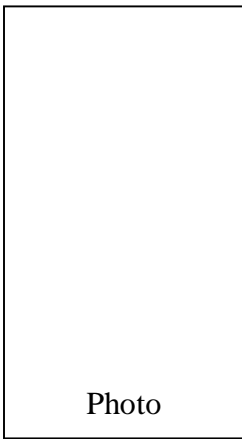
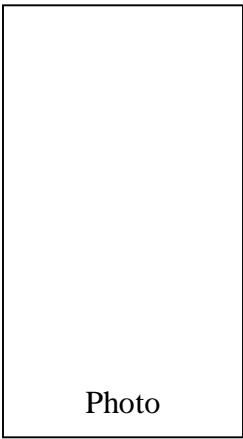
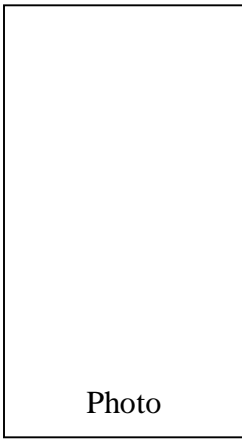

## HOME TEACHING/VISITING TEACHING INFORMATION SHEET

FAMILY NAME ADDRESS & PHONE #	NAMES OF THOSE LIVING AT HOME	EMERGENCY CONTACTS & SPECIAL INSTRUCTIONS
<b>NAME:</b> <b>ADDRESS:</b>  <b>HOME PHONE:</b>  <b>WORK PHONE:</b>  <b>CELL PHONE:</b>	<b>ADULTS:</b>  <b>CHILDREN:</b>  <b>PETS:</b>	<b>EMERGENCY CONTACTS:</b>  <b>PHONE NUMBERS:</b>  <b>SPECIAL INSTRUCTIONS:</b>
<b>NAME:</b> <b>ADDRESS:</b>  <b>HOME PHONE:</b>  <b>WORK PHONE:</b>  <b>CELL PHONE:</b>	<b>ADULTS:</b>  <b>CHILDREN:</b>  <b>PETS:</b>	<b>EMERGENCY CONTACTS:</b>  <b>PHONE NUMBERS:</b>  <b>SPECIAL INSTRUCTIONS:</b>
<b>NAME:</b> <b>ADDRESS:</b>  <b>HOME PHONE:</b>  <b>WORK PHONE:</b>  <b>CELL PHONE:</b>	<b>ADULTS:</b>  <b>CHILDREN:</b>  <b>PETS:</b>	<b>EMERGENCY CONTACTS:</b>  <b>PHONE NUMBERS:</b>  <b>SPECIAL INSTRUCTIONS:</b>

# HOUSE PLAN

It is important for every member of the family to know where important utility valves and shut-offs are located in the house. It is also important to know where important papers, emergency supplies and other important resources are stored. A simple floor plan of each floor of your home drawn on graph paper will be of great assistance. Include in the plan primary and alternate routes of evacuation from all locations in the house. You should also identify the location of all smoke alarms. It is strongly recommended to change batteries in smoke detectors twice a year when clocks are changed at daylight savings time in April and October.

The following should be prominently identified on the floor plan:

- Gas shut-off -
- < Inside the house \_\_\_\_\_
- < Outside the house \_\_\_\_\_
- Water shut-off -
- < Inside the house \_\_\_\_\_
- < Outside the house \_\_\_\_\_
- Electricity shut-off -
- < Inside the house \_\_\_\_\_
- < Outside the house \_\_\_\_\_

Example:

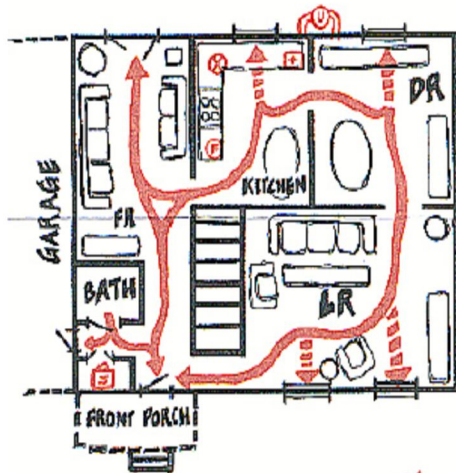

- Normal Exit Route
- Emergency Exit Routes
- Fire Extinguisher
- Smoke Detectors

- Disaster Supplies Kit
- Doors
- Collapsible Ladder
- Reunion Location (Outside)

- Stairways
- Utility Shut Off
- Windows
- First Aid Kit

# EVACUATION PLAN

- If you are asked to evacuate, please do so as quickly as possible.
- Wear protective clothing and sturdy shoes.
- Take your emergency kit, and medications for at least 72 hours. Even though it may appear to you that you will only be gone a few hours, be prepared for longer. Once you leave, you may not be allowed to return home.
- Leash or cage pets and take them with you if possible. However, most shelters will not accept pets. Some animal hospitals may be willing to board your pets. If you take them with you, be sure to take their food, water and other items they will need.  
A possible place to board your pet\_\_\_\_\_.
- Lock all doors and windows. Be sure all appliances (large or small) are turned off; all candles are out.
- Leave a note as to where you have gone and what family members are with you.
- Follow travel routes recommended by local authorities to reach the Evacuation "reception" Center.
- Do not return home until local authorities say that it is safe to do so.

You may be given a few minutes to gather some extra things. Plan ahead so you know what is most important to take with you. Think about things that are irreplaceable in case your home is destroyed and/or you are not able to return, such as **journals, family photos, scrapbooks, family heirlooms, family records**. Write down the things of top priority and their location.

- |           |           |
|-----------|-----------|
| 1. _____  | 11. _____ |
| 2. _____  | 12. _____ |
| 3. _____  | 13. _____ |
| 4. _____  | 14. _____ |
| 5. _____  | 15. _____ |
| 6. _____  | 16. _____ |
| 7. _____  | 17. _____ |
| 8. _____  | 18. _____ |
| 9. _____  | 19. _____ |
| 10. _____ | 20. _____ |

# UTILITY SHUT-OFF

Know how to shut off all your utilities and where the shut-offs are, inside and outside the house.

**1. NATURAL GAS**— Sniff for gas leaks, If you smell gas or there is significant structural damage to your home, turn off the gas.

**“DO NOT TURN OFF IF NO LEAK IS SUSPECTED. If you turn the gas off, you will need a professional to turn it back on.”FEMA**

The meter shut-off valve is located next to the meter. Use a wrench to turn the valve a quarter turn in either direction to the “off” position. Notify the gas company or 911 of the gas leak. **DO NOT** attempt to turn the gas back on!!!

Depending on the severity of the emergency, and the number of meters that have been turned off, you may have to wait some time for your gas service to be restored, even if there is no damage to the gas pipelines in your area.

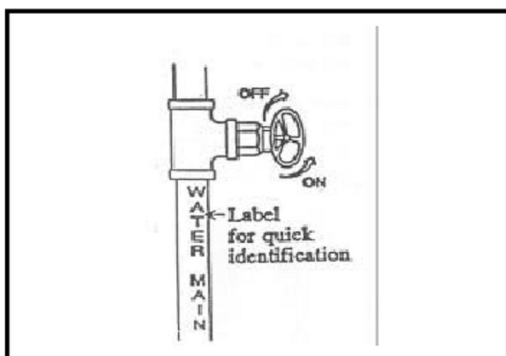
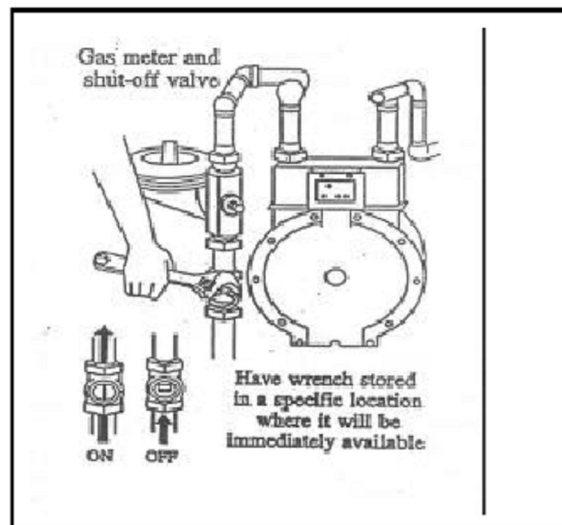

**2. WATER**— Shut off the main water valve to keep contaminated water from entering the house.

If there are water leaks in your home or between your home and the meter, the water valves should be turned off to maintain pressure.

### **3. ELECTRICITY**

If there are downed power lines **STAY AWAY, DO NOT TOUCH!** If you see or hear electrical sparking, **DO NOT TOUCH** or attempt to operate any electrical appliances or switches. If possible, locate the electrical service panel inside your home. Open the metal panel on the box, turn the switches to the “off” position or pullout the main fuse. If you are unable to locate the panel, or unable to get to it, find the electrical “meter” box on the outside your house and turn the switch to “off”.

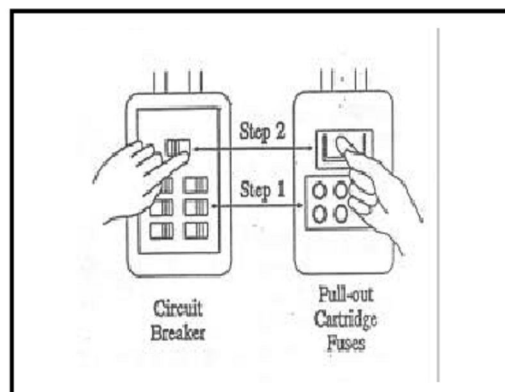

# WATER STORAGE

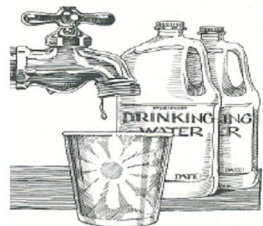

**WHY**—Water is more essential than food in sustaining life. Natural disasters may pollute or disrupt water supplies.

**HOW MUCH**—Store one gallon of water per person per day. Two quarts for drinking and two quarts for food preparation and sanitation. Very hot weather, nursing mothers and children may require more. A minimum two-week supply of water is recommended for your home. 72-hours of water should be available in your EMERGENCY GO KIT. Store as much as possible, at least a minimum of 14 gallons per person.

**HOW**—Store water in plastic food grade containers such as water and beverage bottles. Glass can break and cartons decompose. Water from water beds may be used for sanitation purposes only. Do Not Store in Chlorine bleach bottles and milk bottles.

## HOW TO PURIFY—

1. BOIL vigorously for 3-5 minutes.
2. Add unscented household bleach (5.25% sodium hypochlorite) at the following rate:

AMOUNT OF WATER	CLEAR WATER	CLOUDY WATER
1 quart	2 drops	4 drops
1 gallon	8 drops	16 drops
5 gallons	½ teaspoon	1 teaspoon
55 gallons	2 TBSP	4 TBSP

Stir and let stand for 30 minutes. If the water does not have a slight bleach odor, repeat the dosage and let stand 15 min. Use fresh bleach.

3. Water Purification tablets: (Halizone, or potable aqua.) Different types of tablets are available at drug stores or sporting good stores. Follow the manufacturer's directions. Do not use tablets that are yellowish in color or have a strong odor. Watch expiration dates.

4. Iodine: Use 2% tincture of iodine to purify small amounts of water. Add 3 drops per quart of clear water. Let stand 30 min.

*"Pregnant or nursing women or people with thyroid problems should not drink water with Iodine." Dept of Environmental Quality Division of Drinking Water*

! Stored water goes flat, aerate by pouring it between two containers.

## ADDITIONAL INFORMATION:

! Immediately after a major disaster, prevent contamination of home water supply by shutting off the main incoming water valve. If water from the tap looks cloudy, or has an unpleasant odor, don't take a chance.

**PURIFY BEFORE USING!**

! Clearly label and date all storage containers, especially those reused from other products.

! Consider canned soups, juice from canned fruits and vegetables, bottled soft drinks, bottled juice etc. as sources of liquid.

! Use water stored in the hot water tank, ice cube trays, toilet tank ( not bowl).

! Dirty water can be strained through paper towels or clean cloth to remove particulates, then boil and treat with chlorine bleach as directed.

! There is no effective way for home decontamination of water which contains radioactive or chemical contamination.

! Do not drink water from hot tub or pool, use only for hygiene purposes.

# FOOD STORAGE

## STORE WHAT YOU EAT -- EAT WHAT YOU STORE

### DATE AND ROTATE AS YOU GO!

Use storage areas that are well ventilated, cool, dark, dry and clean

These basic items should be considered for storage. They provide adequate calories, protein, vitamins and minerals. Note the approximate storage life and the suggested amount needed to sustain one person's life for one year (if no other foods are added).

THE BASICS			
Item	Storage Life	*Suggested Amount 1 adult per 1 year	Suggested Amount 1 adult per 1 month
Grains (Wheat, Flour, Rice, Corn, Oatmeal, Pasta)	varies	400 lbs	33.3 lbs
Legumes (Dry beans, peas, lentils)	6-8 years	60 lbs	5 lbs
Powdered Milk	2-3 years	16 lbs = 64 quarts	1.3 lbs
Sugar/Honey	20+ years	60 lbs	5 lbs
Salt	20+ years	5-8 lbs	0.5 lbs
Oil (shortening, butter, mayonnaise, p-nut butter)	2+ years	20 lbs = 10 quarts	1.6
**Water	Indefinite	14 gal/person/2wk	

\*These amounts are suggested by The Church of Jesus Christ of Latter Day Saints. For more information go to [www.providentliving.org](http://www.providentliving.org)

\*Children's % of adult portion: 0-3yrs =50%; 4-6 yrs = 70%; 7-10 yrs = 90%

\* Start using wheat and whole grains in diet regularly to allow digestive system to adapt to increased roughage.

\*\*It is impractical for most families to store a year's supply of water. Fourteen gallons per person is a suggested minimum reserve.

Successful food storage depends on several factors:

- Quality of products - obtain top grade food products when possible
- Proper Containers - use heavy plastic, metal or glass with tight fitting lids
- Storage areas - easy access, dark, cool, dry, free from rodents insects/other pests
- Temperature - food stores best at 40-60E F
- Variety - provides better nutrition and avoids appetite fatigue
- Rotation - date and rotate to minimize loss of food value and flavor, prevent spoilage
- Inventory - Maintain a record of items used and added to

Begin with the basics that are life sustaining and store well for long periods of time. Then add other foods for variety, interest and personal preference. Expanded storage could include such items as meats, fruits and vegetables, (canned, bottled, frozen, dehydrated, pickled or smoked).

Also include spices, flavorings, cornstarch, baking powder, soda, and yeast.

Consider your families likes and dislikes, allergies and needs when deciding what to store.

It is better to have food storage for a short period of time than none at all!

# 72 HOUR EMERGENCY KIT

*The following emergency preparedness kit should be kept cool, dry, and readily accessible for rapid exit. It could be stored in easy to carry backpacks, duffle bags, suitcases, or 5 gallon buckets. Include a master list in the top of each kit with date prepared. A copy of this page with checkmarks or notes works well.*

## **Water**

1 gallon per person per day (# of family members  
\_\_\_\_\_ X 3 days = \_\_\_\_\_ gallons needed)

Water Purification Tablets or chlorine bleach

## **Equipment**

Adjustable wrench - hammer - Pocketknife

Battery powered radio (extra batteries)

Fire Extinguisher (very small)

Flashlight (extra batteries) - light stick

Folding shovel

Plastic- 2 sheets 9' x 12'(shelter, ground cloth, water collection)

Rope (1/4 x 26') - duct tape

Tent - Tarp (Shelter)

Whistle -1 per person

Work gloves

## **Sanitation**

Plastic bucket with tight fitting lid

Plastic trash bags (large & small, also zip locks)

Disinfectant (bleach, lysol, pwd. chlorinated lime)

Toilet paper - Soap/Towel

## **Cooking/Heating**

Aluminum Foil

Buddy burners/sterno/alcohol stove/backpack stove

Candles-2 large

Can opener - manual

Dish soap/Dish cloth/towel

Knife

Matches in foil or waterproof container

Mess kit (1 per 2 people)/ Pan for cooking/washing

Metal cup -Pan, can or small tin pail

Paper plates/cups/napkins/plastic utensils

Spoon & Fork - Metal for mixing

## **Stress/Morale Boosters**

Scriptures

Ball, small games, crossword puzzles, cards

Hard candy, chocolate chips

Harmonica/Needlework/pictures

Paper, pencils, crayons, permanent marker

## **Food for 3 days**

Baby Food- baby cereal -formula - juice

Beef Jerky - Canned meats: tuna, spam,

Candy - hard candy, lollipops, gum

Canned fruits/vegetables - juice

Canned Foods -chili, pork&beans, ravioli, soup, spaghetti, stew,

Cereals (Oatmeal, cracked wheat, sweetened)

Crackers - cookies

Dry Soup Mix - Ramen Noodles -

Dried Fruits - raisins, trail mix, Fruit roll-ups

Granola Bars - peanuts, trail mix

MRE's (Meals Ready to Eat)

Peanut butter, jelly, honey

Powdered milk/Cocoa mix

## **Clothing/Bedding (seasonal)**

1 space blanket per person

Wool /fleece blanket or sleeping bag (1 per person)

1 change of clothes: include underwear & 2 pair socks (at least 1 wool), sweatshirt, gloves, shoes

Infants: disposable diapers, pacifiers, blankets, clothing

## **Hygiene**

Comb & brush (Hair needs: barrettes, clips, elastics)

Deodorant, Lotion

Feminine Hygiene needs

Lip balm, chap stick, Blistex, Tube of Vaseline

Nail clippers, nail file

Shaving supplies

Shampoo

Small mirror

Soap (preferably liquid, if bar, it needs a container)

Toothbrush/toothpaste

Washcloth/towel

## **Other**

First Aid Kit

Insect repellent/Sun screen

Money - (Coins, small bills, credit card)

Safety pins, needle, thread, scissors, buttons

Extra Glasses - Extra set of car keys

Keep the families most valuable documents (or copies) in your emergency kit or in a packet ready to pick up and take with you: deeds, mortgage, titles, insurance, wills, home contents & pictures, social security numbers, drivers license or ID cards, birth cert., account numbers, genealogy, current pictures of family members, Name, address, & telephone number of out of state contact, other phone numbers. All this information could be put on one 3½" computer disk, CD or flash drive. It is also suggested to have copies of the above documentation stored with family members across town or out of state.

# Infants/Toddlers/ Senior Citizens/Pets

*Infants and children have special needs in a 72 hour kit. Items should include:*

Their own bag - labeled with their own name  
Disposable diapers (36 -48 minimum)\*  
Disposable wet wipes\*  
Plastic garbage bags\*  
Two changes of clothes\*  
Two pair pajamas  
Two blankets  
Hat/gloves/socks  
Infant formula (May need to supplement nursing babies)  
Instant baby cereal  
Canned food & juices - must be eaten at one meal to prevent spoilage  
Teething biscuits & Orajel  
Sterilized water/also Pedialyte  
Plastic bottles (label with name)  
Disposable bottle liners  
Extra nipples  
Bib  
Plastic spoon and bowl  
Pacifier (Label with name)  
Safety pins  
Baby powder  
Baby Oil  
Diaper rash medication  
Children's Tylenol  
Assorted toys (label with name)

## Senior Citizens

In addition to preparing a 72 hour kit:  
< Arrange for someone to check on you  
< Have a plan to signal the need for help  
< Have extra batteries for hearing aids, wheel chairs, extra oxygen, extra eyeglasses  
< List the style and serial numbers of medical devices such as pacemakers, and a list of all medications and dosages  
< Teach those who may need to assist you how to operate necessary equipment.

The most critical aspect of infant care during emergencies is sanitation. Infants, by nature, become soiled and dirty from one minute to the next, thus providing excellent breeding grounds for disease-causing bacteria which may infect not only the infant but also adults that come in contact.

\*For proper sanitation, it is important that you store a sufficient supply of disposable diapers, wipes, and garbage bags. Change infants regularly and keep them clean. Dispose of the soiled diapers in the garbage can liners and keep them tightly sealed to prevent spread of disease. Wash hands often.

Emergency diapering needs may be met by lining plastic pants with scraps of cloth, tissue, paper towels, or other absorbent material.

Before the emergency, young children can help prepare and store supplies. Teach them about the warning sounds (smoke alarms, sirens, etc in your home & neighborhood)

Young children should memorize family name, address, and phone number as early as possible. Children need extra reassurance - take time to hold, cuddle, talk and especially listen to them. Encourage them to talk about their feelings. Keep them with the rest of the family. Be prepared to sing songs and play simple games such as I Spy; Duck, Duck Goose; Button, Button; Lion Hunt; etc.

## Pets

Consider your pet's needs in planning for an emergency.

- < Have a current ID tag, license.
- < Keep their vaccinations current.
- < Keep pet carriers, extra collars, and leashes on hand to contain and calm your pet.
- < Your pet also needs ½ gallon of drinking water per day
- < Store at least 2 weeks supply of food

In case of evacuation, be aware that pets are not allowed in Red Cross emergency shelters.

# IMPORTANT NON FOOD ITEMS FOR STORAGE

## Tools

Adjustable wrench/hammer & nails  
Ax/Saw  
Bailing Wire/ Twine  
Broom/dustpan  
Bucket  
Clothesline and clothes pins  
Crowbar  
Gloves (Heavy Work)  
Pliers  
Rope – heavy duty  
Screwdrivers  
Shovel  
Tape (Duct/plastic/electrical)  
Tarps

## Cooking

Aluminum Foil (Heavy Duty & regular)  
Bucket or dishpan  
Canning lids/paraffin wax)  
Can opener (non-electric)  
Campstove & Fuel  
Charcoal & lighter fluid  
Dish cloth/ dish towel/scrubbie  
Dish detergent  
Dutch oven  
Napkins/paper towels  
Paper plates/cups/utensils  
Plastic wrap/wax paper/zip lock bags, coffee filters  
Pots/pans (at least 2)  
Sharp Knife  
Utensils

## Bedding

Blankets/quilts (enough to keep each person warm with no other heat source)  
Pillows  
Rubberized Sheets  
Sheets (Flannel are warmer & more absorbent)  
Sleeping bags

## Clothing

Boots – extra laces  
Gloves – warm and seasonal  
Jacket/ Warm Coat  
Poncho - Seasonal Clothing  
Shoes/2 socks (at least 1 pair wool)

## Safety Items

Batteries - many sizes  
Candles  
Flashlights  
Fire Extinguisher  
Garden Hose (firefighting/ siphoning gas)  
Insecticides  
Lantern & Fuel – extra mantels  
Matches/lighters  
Paper & pencils  
Radio (battery operated)  
2 way radios and batteries

## Sanitation

Large trash can w/ tight fitting lid  
Ammonia  
Bleach  
Clean rags  
Disinfectant (Lysol, Pinesol, etc)  
Newspapers (to wrap garbage & waste in, could also be used for fuel or blankets)  
Plastic bags (various sizes especially garbage bags)  
Toilet paper  
Wet Wipes

## Hygiene Supplies

Combs/brushes  
Contact Lens solutions  
Deodorant  
Extra Glasses  
Feminine Supplies  
Hand soap (15 bars/person/year)  
Infant Supplies (Disposable diapers, plastic pants, bottles)  
Laundry detergent (25 lbs/person/year)  
Shampoo/Conditioner  
Shaving supplies  
Tissue  
Toothbrush/toothpaste  
Wash Cloths/Towels

## Pets

Food  
Leashes/collars  
Litter box supplies  
Medications

# ALTERNATIVE HEAT, LIGHT, & POWER SOURCES

\***FIRE STARTERS** - store matches (waterproofed), butane lighters, flint & steel, charcoal starter.

\***FIREPLACE, OPEN FLAME** (Campfire or Outside Fire Pit) suspend a Dutch oven over the heat by using a tripod, much like the early settlers did, or set the Dutch oven directly on the hot embers you have made in the fireplace or outside campfire.

\* **WOOD BURNING - COAL STOVES** use frying pans or pots on top to cook your meal.

\* **GAS CAMP STOVES** (white gas, gasoline, kerosene, propane) - Two burners using white gas will operate 4 hours on 1 quart.

Use outdoors only.

\* **BARBECUE GRILL** with 5 gallon tank of propane, stores well and is easy to use.

\* **STERNO** works well for small quantities of food .

\* **VOLCANO** is a type of outdoor cook stove that you can use with 2 Dutch ovens and charcoal. It is very fuel efficient, using about half of the charcoal you would use normally with your Dutch oven. A few briquettes can roast, fry, bake, etc.

\***DUTCH OVENS** a 10" dutch oven with 6 or 7 briquettes on the lid and 5 or 6 underneath will cook a pot full of food. Use outdoors only.

\* **HIBACHI** - Four or five charcoal briquettes in an 8"x8" Hibachi will generate enough heat to cook a simple meal. Should only be used outdoors.

\***ALCOHOL STOVE** - Place 1 roll of Toilet paper in 1 quart paint can - pour Isopropyl rubbing alcohol over the TP and light with a match. The can will not get hot on the bottom until the alcohol has burned down.

Extinguish the flame, add more alcohol and relight. Control the intensity of the heat by adjusting the lid.

\***CHARCOAL STOVE** - Turn a #10 Can into a charcoal stove. Cut out top and bottom of the can. Punch holes around the top and bottom. Punch many holes in the lid and wire it about half way up the can. Place the charcoal on it to light. Use a sturdy piece of wire screening, or crisscross wire across the top to create a cooking rack.



\***FLASHLIGHTS:** New batteries last 6-7 hours of continuous use. Six-month old batteries last 5-6 hours.

\***CANDLES:** ¾"x4" will burn 2 hrs 20 min.

\***COLEMAN MANTLE LANTERN:** Two mantle lantern will burn 5 hours on ½ quart of white gas.

\***KEROSENE LANTERN:** With a 1 inch wick will burn 45 hours on 1 quart of kerosene.

\***LIGHT STICKS** are safest emergency light

\***GENERATORS** are an excellent source of safe power. However, they use a great deal of fuel. Most run on gasoline, burning ½ to 3 gallons per hour. Itemize energy requirements in order to select the appropriate size needed. Use the smallest size possible for less fuel needs.

Operate generators in an open area with good ventilation. DO NOT ATTACH the generator to your house current without approved transfer switches. The electrical "back feed" can injure or even kill utility workers repairing the power lines.

For more information and or to calculate wattage needed go to

<http://www.powerprotection.org/powergeneration/portablegenerators>.

# OTHER EMERGENCY KITS

## **Basic Minimal First Aid Kit**

2 pairs of Latex gloves (or other sterile gloves if you are allergic to latex)  
Sterile Dressings to stop the bleeding  
Adhesive Bandages in a variety of sizes  
Cleansing Agent or soap  
Antibiotic Ointment to prevent infection  
Burn ointment  
Tube of Petroleum Jelly or other lubricant  
Eye Wash solution to flush the eyes  
Triangle Bandage  
Waterless Alcohol Based hand sanitizer or Germicidal Handwipes  
Thermometer  
Scissors  
Tweezers  
Personal Medications including a list of all medications and dosages  
Non prescription drugs (Aspirin and non aspirin pain reliever, Anti diarrhea medication, antacid, laxative, Syrup of Ipecac)

## **Office Emergency Kit**

*Keep a backpack or tote bag under your desk for any emergency use.*

*In case of emergency you could be stranded at your office for several days. Plan for at least 72 hours.*

Blanket, flat sheet, pillow or sleeping bag  
Change of clothes, socks, shoes, undies  
Coat or Jacket  
First Aid Kit  
Flashlight & extra batteries  
Food - non perishable -  
Hygiene supplies - trial size lotions soaps, shampoo/conditioner, toothpaste, toothbrush, mouthwash, toothpicks  
List of family names and telephone #'s  
Medications  
Sweet hard candy  
Towel, washcloth  
Water - clear liter bottles  
Whistle with lanyard to hang around neck

## **Car Survival Kit**

*Not all items are mandatory, but could prove useful.*

*Always maintain at least 1/2 tank of gas!*

Bag of sand or rock salt  
Blankets or sleeping bag  
Bottled Water (2 Liter)  
Candles  
Car tool kit (pliers, screw driver, hatchet, folding shovel, wire saw, nails, twine, wire, tape, file)  
Clothes, including boots, socks, hat, etc.  
Compass  
Fire extinguisher (Standard class ABC)  
First aid kit and manual  
Flashlight & extra batteries  
Fold up Stove & fuel tablets  
Food - non perishable  
Gloves (work gloves & rubber disposable gloves)  
Ice Scraper for winter season  
Jumper Cables  
Map  
Matches  
Mirror  
Paper, Pencils  
Pre-moistened towels  
Portable radio & batteries  
Reflectors, flares  
Rope  
Sewing Kit  
Short rubber hose for siphoning  
Space blanket  
Tissues  
Tow Rope  
Waterproof matches  
Whistle  
Zip lock bags



# Basic List of Medical and First Aid Supplies

## **Bandaging**

Ace bandages – assorted sizes  
2", 3" 4" gauze rolls  
sterile dressing assorted sizes  
1" tape - cloth, plastic or paper  
Band-aids – variety including:  
Assorted sizes of strips  
Butterfly bandages  
Extra large  
Fingertip/Knuckle  
Sanitary napkins, individually packed  
Super Glue for wound closure  
Triangular bandages

## **Colds**

Antihistamine/decongestants  
Cold medicine of choice  
Cough lozenges &/or syrup  
Vitamin C - & others as desired

## **Disinfectants**

Alcohol  
Alcohol preps individually wrapped  
Gel hand sanitizer – waterless  
Hydrogen peroxide  
Bar soap  
Triple antibiotic ointment (neosporin)  
Water purification tablets

## **Eye Care**

Lubricating eye drops  
Contact lens solutions  
Ophthalmic antibiotic ointment –RX only

## **Gastrointestinal Relief**

Antacids – liquid or tablets  
Anti-nausea- i.e. Dramamine  
Diarrhea medicine i.e. Immodium  
Glycerine suppositories  
Laxative  
Pepto Bismol &/or Alka-Seltzer

## **Insect bites and stings**

Baking soda  
Benadryl –for allergic reactions  
Calamine or Caladryl lotion

## **Ointments**

KY jelly – water-soluble  
Mentholatum  
Petroleum jelly  
Zinc oxide

## **Pain Relief**

Aspirin & non-aspirin pain reliever  
Earache/toothache drops  
Prescribed medicines  
Tylenol drops for babies if needed

## **Skin Rashes-Allergic reactions**

Antihistamine tablets & syrup  
Benadryl or Caladryl  
Hydrocortisone cream  
Prescribed medicines i.e. Epi pens

## **Miscellaneous**

Favorite home remedies  
First aid manual  
Lip balm  
Insect repellent  
Personal medications and equipment – i.e. insulin,  
and syringes, heart meds etc.  
Sun screen and block  
Splints and slings

## **Tools and Equipment**

Container - tackle box, plastic box etc.  
Collapsible drink cup/paper cups  
(Consecrated oil - if LDS)  
Dental floss  
Gloves - Heavy-duty work & Latex  
Instant ice pack  
Matches – waterproof container  
Medicine dropper/dose cups  
Q-tips  
Penlight & batteries  
Pocket knife - sharp  
Pocket mask - other barrier device to use in CPR  
Scissors – bandage & heavy duty  
Sewing needles/thread, Safety pins  
Splinting materials  
Thermometer  
Tongue depressors – (many uses)  
Tweezers

# FIRST AID BASICS

First Aid and CPR classes are routinely available in the community through Red Cross. CERT classes are taught regularly and teach important disaster response skills. Plan to register for an upcoming class. In addition, Emergency 911 dispatchers are trained and able to give patient care instructions while awaiting the ambulance. Stay calm and stay on the phone until they conclude the call upon the arrival of medical personnel.

## The ABC's to providing first aid...

### Airway---

Without proper airway positioning and maintenance, anything else you might try to do for the victim will be in vain. If the victim is conscious, talking or breathing, the airway is assumed to be clear. If snoring sounds are heard, it could signal a partially obstructed airway and steps must be taken to secure a better airway. If the victim is not breathing, make sure there are no obstructions in the victim's mouth and that the head is tipped back to open the airway. Reposition the victim on his or her back, making sure to keep the head in line with the spine, and turning the victim as one unit. Get help if possible.

### Breathing---

If upon repositioning and securing the airway the patient does not start to breathe, begin rescue breathing.

### Circulation-

Circulation includes the pumping of the heart as well as controlling bleeding. If no pulse is detected, CPR is needed. Most bleeding can be controlled by placing a bandage and applying direct pressure. If the bleeding is not controlled, do not remove bandages. Simply apply another layer of bandaging material. If bleeding is still not controlled, consider elevating the limb and/or applying pressure to the pressure points.

## First Aid Basics continued

Recognizing an emergency and taking action in the first few minutes can mean the difference between death or life-long injury and full recovery.

- Check the scene for safety. Do not become a victim of an unsafe scene! Make the scene safe before proceeding.
- Check the victim's level of consciousness or responsiveness, airway, breathing, circulation.
- Call 911—**stay calm** -be prepared to give:
  - exact location;
  - Caller's name;
  - What happened &
  - how many are involved
  - Condition(s) of victim(s)
  - What help is being given
- Call 911 if the victim:
  - Is or becomes unconscious
  - Has trouble breathing
  - Has chest pain or pressure
  - Is bleeding severely
  - Has seizures, severe headache, slurred speech
  - Appears to have overdosed or been poisoned.
  - Has injuries to the head, neck or back
- Call 911 if the situation involves:
  - Fire or explosion
  - Downed electrical wires
  - Swiftly moving/rapidly rising water
  - Presence of poisonous gas.
  - Vehicle collisions
  - Victims who cannot be moved
  - Care for the victim, reassure, and keep them warm. Watch for changes.

## The four basic life saving steps are:

1. Start the breathing (CPR)
2. Stop the bleeding
3. Protect the wound
4. Treat for shock

# SANITATION

During emergencies, sanitation becomes a real problem and can be the cause of disease. In an emergency, hygiene is even more important! **Wash your hands frequently!** Substitutes for cleansing without water include: Purel, rubbing alcohol, lotions containing alcohol, shaving lotion, face creams and lotions, towelettes, (baby wipes), a wet washcloth.

**Toilet with a bag:** Remove the water from your toilet bowl and line it with 2 sturdy trash bags. When ½ full remove the 1st bag, tie it securely for disposal and store in a covered trash can until disposal service is resumed.

## **SANITATION KIT** (Store in 5 or 6 gal bucket)

- (1) 5 or 6-Gallon bucket with tight fitting lid
- Snap-on type toilet seat with lid
- (12) plastic liners (garbage bags)
- (4) pairs of rubber gloves
- (2) rolls of toilet paper
- Disinfectant: Liquid chlorine bleach, Nilogel clean-up gel, Pinesol, Powdered laundry soap, powdered chlorinated lime available at building supply store. It can be used dry. Be sure to get chlorinated lime and not quick lime which is highly alkaline and corrosive.
- (1) bottle of 3% Hydrogen Peroxide
- (1) box of Baking Soda
- (1) ½ gallon of white vinegar
- (1) large bottle of a hand sanitizer
- (1) roll paper towels
- (1) pkg. Baby Wipes
- (1) 2 liter bottle of water
- 6 or 10 gal container with tight fitting lid
- A supply of old newspapers for wrapping garbage
- 2-3 spray bottles
- Feminine Hygiene items

## **DIRECTIONS FOR EMERGENCY TOILET:**

1. Put 2 garbage bags as a liner in the 6-gallon bucket, and snap on the toilet seat.
2. Sprinkle one tablespoon of Nilogel (or other disinfectant) in the bucket. The Nilogel will absorb over 100 times its own weight (up to two gallons of liquid). The liquid becomes a gel and will deodorize the toilet contents. The gel is also biodegradable. If using other disinfectant sprinkle some disinfectant on top after each usage.
3. The toilet is ready to use. Use toilet paper as usual.
4. Use baby wipes or hand sanitizer on hands after each use and dry hands with paper towels.
5. Replace the tight fitting lid after each use of the toilet. The key to disease control is to KEEP IT TIGHTLY COVERED.

6. When the bag is ¼ to ½ full, carefully remove the first bag, tie it together and place it in the larger container. Use rubber gloves.

7. Replace liner so the bucket remains double bagged.

**Disinfectant:** When using bleach use ¼ cup bleach to 1 quart water. Other commercial disinfectants include HTH, or calcium hypochlorite, which is available at swimming pool supply stores; also portable toilet chemicals are available through recreational vehicle supply stores.

Never deposit waste or garbage on open ground. "In times of emergency, the military procedure, is to bury human waste in trenches 24"-30" deep, and cover with a thin layer of lime."

(Earthquake Preparedness, 1989, pg 16)

Garbage should be drained and wrapped in several thicknesses of old newspaper to absorb extra moisture, it can be stored longer before developing unpleasant odors. A tight fitting lid is important to keep out flies. Other rubbish, trash that will not decompose may need to be burned, (with permission from local authorities).

## **ADDITIONAL SUPPLIES FOR DISINFECTING AND ODOR CONTROL:**

**Baking Soda:** will help to control odor; it stops mold, fungus or mildew, and is a natural Whitener. Baking soda relieves heartburn, indigestion and it neutralizes acids in a sour stomach associated with diarrhea. Use 1 teaspoon of baking soda mixed with 1 cup of water and drinks it down. Baking soda plus a little salt will help clean your teeth.

**3% Hydrogen Peroxide** (Put in a small spray bottle, no water added) Hydrogen Peroxide is an antiseptic, and a cleaning agent for minor cuts and abrasions. It can be used as an oral rinse and gargle. To disinfect toilet seat just spray it on and wipe off.

**White Distilled Vinegar:** Put in a small spray bottle, no water added. Studies show that vinegar kills 99% of bacteria, 82% of mold, and 80% of germs (viruses). To disinfect toilet seat just spray it on and wipe off.

## **COMBINING VINEGAR AND HYDROGEN PEROXIDE:**

Spraying solutions of vinegar and hydrogen peroxide, one after the other, in any order, kills virtually all Salmonella, Shigella or E. coli bacteria on heavily contaminated surfaces.

(*Science News* 8/8/98; Vol 154, Issue 6 pg 83-85)

# COMMUNICATIONS

In a wide scale disaster or emergency, the most common means of communication will probably not work. If they do, you will be able to call out of state more easily than locally. Thus, all members of your family should know or have the number of an "out of state contact."

Telephones, cellular phones, and pagers will likely be unavailable or of little use. Be sure to keep a cell phone charger in your car just in case.

Walkie-talkies or 2 way family radio service (FRS) radios, and CB radios may be very useful, but are likely to experience heavy usage. A supply of batteries is advisable.

Rechargeable batteries may be unuseable if there is no power. GMRS radios have a longer range - about 5 miles.

Amateur (HAM) Radio may be operational but operators must be licensed.

Battery powered standard AM and FM radios will provide emergency alerts and messaging for our area. Radio may function when other forms of communication do not. Tune to KSL 1160 AM Radio.

CERT Volunteers or runners may be used to communicate and coordinate response activity.

# Essential Documents

To be prepared for emergencies, there are some important financial and legal documents you need to keep safe in a place where you or your heirs can get them. Sometimes a copy is not the same as the original and does not have the same validity.

\*It is necessary to have the original or a certified copy.

- \*Living Wills, \*Powers of attorney and \*Medical powers of attorney
- \*Wills and trusts
- \*Titles and Deeds
- \*Birth Certificates/\*Adoption decrees/\*Naturalization Records
- \*Marriage License/divorce papers and child custody papers
- Passports and military/veteran papers
- Social Security cards, Drivers License or ID cards

- Certificates for stocks, bonds, investments
- Insurance policies (life, home, auto)
- List of health and medical information
- List of financial investment information including account numbers
- Important contact information (family, friends, doctors, attorneys, ins. agents)
- Household inventory documentation
- Mortgage
- Genealogy, pictures, and Family History

This information could be put on a 3½ disk or CD. **CAUTION!!!** This information must be safeguarded and protected. This information in the wrong hands would make identity theft very easy.

## How to make your home safer during earthquakes

Most injuries, deaths and economic loss in an earthquake are due to man-made problems. Many of the solutions, which limit loss, are simple and inexpensive. If building a new home or considering retrofitting an existing home for seismic protection, seek help from a professional contractor specializing in seismic construction techniques. In the mean time consider the following suggestions to reduce damage to your property in the event of an earthquake.

**Secure fixtures such as lights, cabinets, bookcases, and top-heavy objects to resist moving, coming loose, or falling during the shaking. Place hard and heavy objects on lower shelves and securely fasten shelves to walls. Special care should be taken to remove objects from above sleeping areas. Do not hang plants in heavy pots that could swing free of hooks.**

### Secure your furniture

by using: "L" brackets, corner brackets or "anodized aluminum molding to attach tall or topheavy furniture to the wall. Corner brackets or eye bolts to secure items located a short distance from the wall. Attach a wooden or metal guardrail on open shelves to keep items from sliding or falling off. Fishing line can be used as a less visible means of securing an item (guardrail).

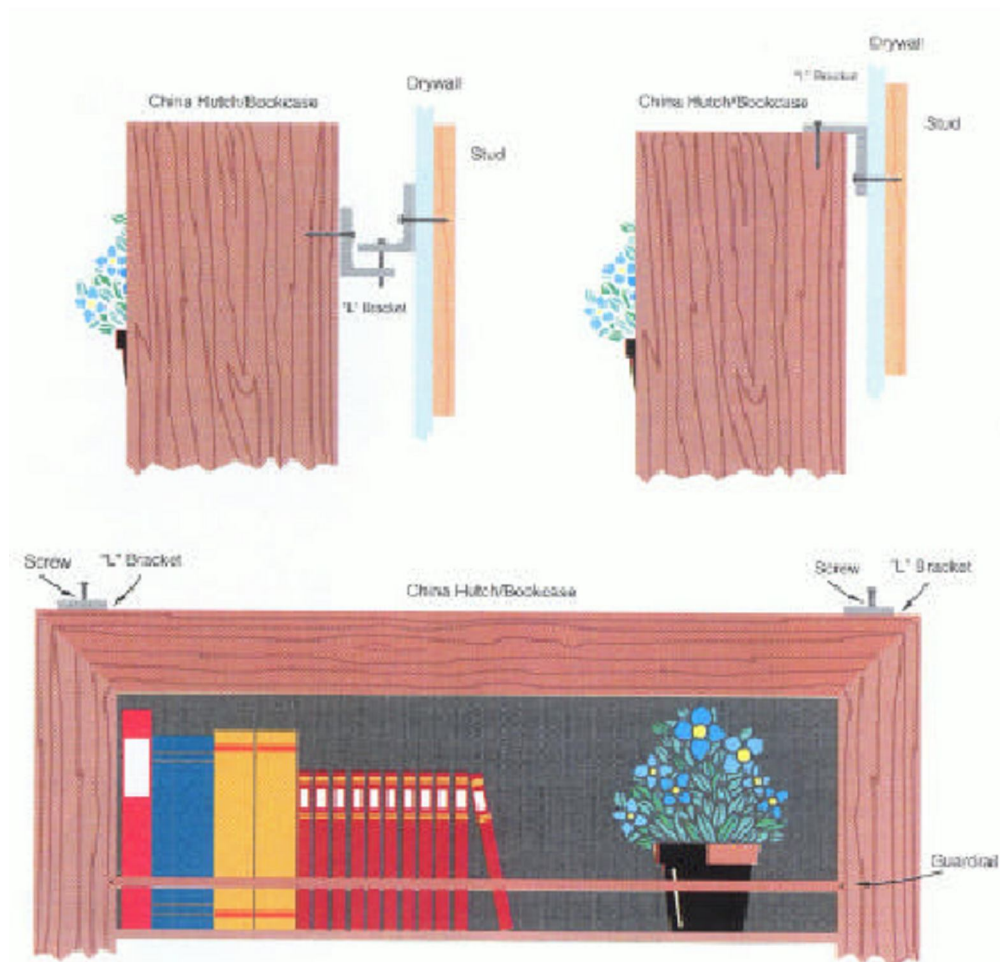

**Store bottled goods**, glass, vases, china, and other breakables in low or closed cabinets and use non-skid padded matting, hold fast putty, or Velcro whenever possible.

**Check the electrical wiring and connections to gas appliances.** Defective electrical wiring, leaking gas or inflexible connections are very dangerous in the event of an earthquake.

**Develop a family plan**, which addresses what to do if the earthquake occurs while family members are at home, school, or work. This plan should include a possible central meeting location for family members after the earthquake and an out-of-area contact person so other family members can find out information concerning their loved ones in the disaster area. It is usually easier to call out of a disaster area than it is to call into one.

**Hold practice drills** so each member of your family knows what to do in an earthquake.

**Locate master switch and shut-off valves for all utilities** and teach all responsible family members how to turn them off.

**Is the water heater securely strapped in place?** Strapping the water heater to wall studs and having flexible gas and water lines installed will greatly reduce the risk of fire and water damage in an earthquake.

### Water heater in corner or closet

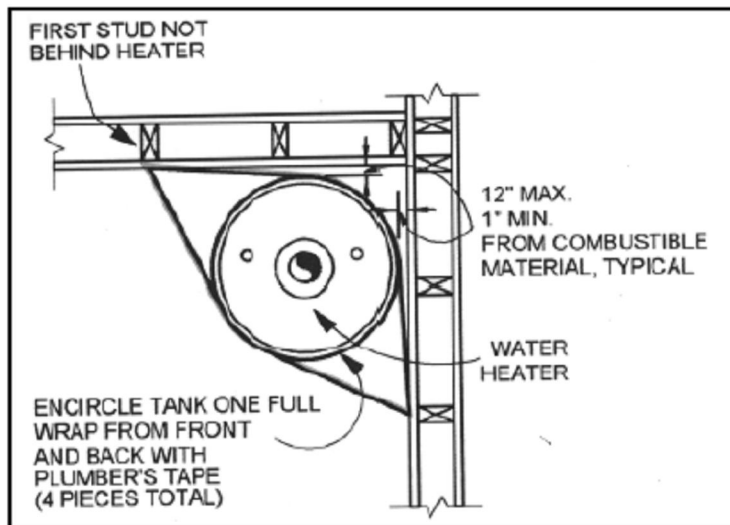

Overhead view of water heater in corner

### Materials

$\frac{3}{4}$ " x 24 gauge perforated steel plumber tape

- $\frac{1}{4}$ " diameter x 3" lag screws and flat washers or  $\frac{1}{4}$ " expandable anchors with 2" embedment for concrete or masonry walls

### Directions:

- The water heater should be 1" to 12" away from the corner walls.
- Locate the wall studs on both sides of the water heater (not behind it).
- Anchor plumber's tape (a flexible steel strap) to a wall stud with a 1/4" diameter x 3" lag screw and flat washer.
- From about 9" from the top of the tank, wrap the plumber's tape all the way around the tank in a clockwise direction. Then anchor the tape to the stud on the other wall. Make sure the tape is tight.
- Repeat the process, again about 9" from the top of the tank, but this time wrap the tape in a counter clockwise direction.
- Repeat the process two more times about 4" from the bottom of the tank. Wrap one band of tape in a clockwise direction and the other band of tape in a counter clockwise direction.

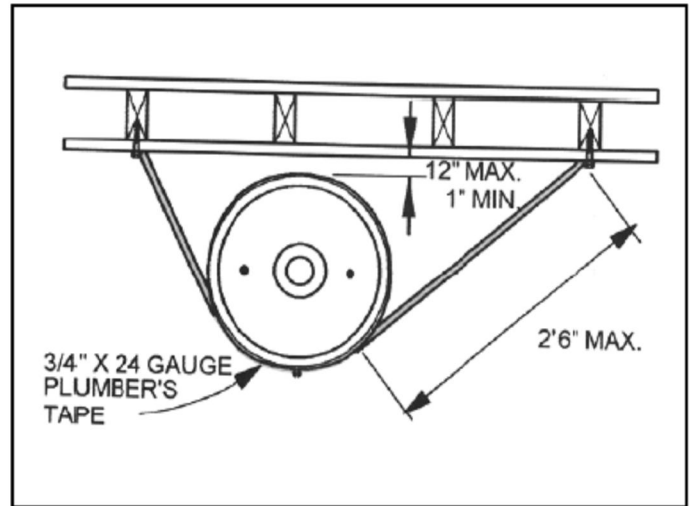

Overhead view of water heater on straight wall

## Water heater on straight wall

### Materials

3/4" x 24 gauge perforated steel plumber's tape

1/2" diameter conduit

1/4" diameter x 1" round head machine screws with nuts and flat washers

1/4" diameter x 3" lag screws and flat washer or 1/4" expandable anchors with 2" embedment for concrete or masonry walls

### Directions

- The water heater should be 1" to 12" away from the wall.
- Locate the wall studs on both sides of the water heater (not behind it).
- Wrap plumber's tape around the tank 9" from the top and 4" from the bottom. Secure tape with round head machine screw, flat washers and nut.
- Cut four pieces of conduit to size. The conduit is used as angle bracing from the wall studs to the tank. Flatten 1" at each end of the conduit and bend 45 degrees. Drill holes 1/2" from each end.
- Anchor the conduit to the wall studs. Use 1/4" diameter x 3" lag screw and flat washer. Then anchor the conduit to the plumber's tape. Use 1/4" diameter x 1" round head machine screw, washer and nut. If you're using gas, have your utility company or a licensed plumber install a flexible hose where the gas line connects to the water heater at its base. Install flexible hoses for the water connections as well.

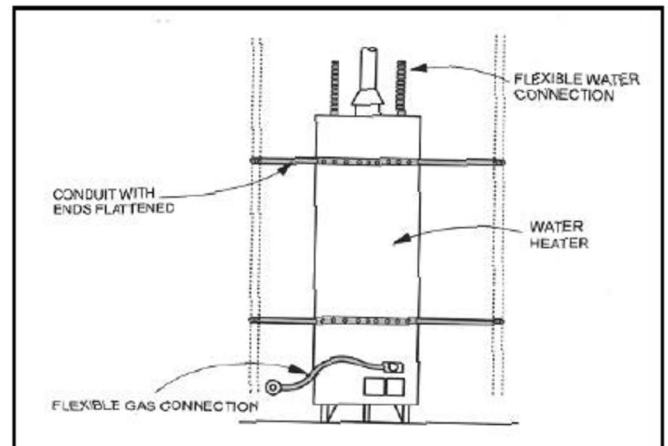

Side view of water heater on straight wall

# EMERGENCY BASICS

## I. BEFORE an Emergency:

1. Know how to turn off gas, water and electricity to your home.
2. Know Basic First Aid.
3. Have a "72 Hour Emergency Kit" readily available.
4. Keep your car 1/2 full of gas.
5. Have a plan for reuniting your family - one place right outside your home and another outside the immediate neighborhood.
6. Have an "out of area" contact person - every family member needs to know the number or have it with them.
7. Have operational smoke alarms, carbon monoxide alarms and fire extinguishers installed.
8. Children at school - make sure your list of adults authorized to pick up your children is current and complete. Tell older children who self transport to follow the instructions of authorities.
9. Know your neighbors, their skills and their needs Plan how you could help each other - special needs, elderly, disabled, child care if children come from school and parents cannot get home. Working together as neighbors can save lives and property.
10. Have a "**Home Hazard Hunt**" -
  - ! Repair defective electrical wiring and leaky gas connections
  - ! Secure water heater with straps to stud walls
  - ! Fasten shelves securely
  - ! Place large heavy objects on lower shelves
  - ! Hang pictures and mirrors away from beds
  - ! Brace overhead light fixtures, china cabinets, bookcases, top heavy objects
  - ! Store weed killers pesticides and flammable products away from heat
  - ! Clean and repair chimneys, flue pipes, vent connections and gas vents
  - ! Place oily rags or waste in covered metal cans
  - ! Clear surrounding brush or weeds 30' from home
  - ! Take care of anything that could move, fall, break, or cause a fire

## II. DURING an Emergency

1. STAY CALM, REASSURE OTHERS (especially young children), THINK through the consequences of any action.
2. DO NOT TIE UP TELEPHONE LINES needed for emergency operations.
3. LISTEN to portable radio for ALL weather service advisories.  
KSL 1160AM
4. REMAIN INDOORS, Stand in hallway, strong interior doorway or take cover under a desk or table away from glass.
5. FOLLOW ADVICE OF LOCAL AUTHORITIES.  
If you are told to evacuate, do so promptly. If told to go to a certain location, go straight there and check in.

## III. AFTER an Emergency.

1. Check for injuries - provide First Aid
  2. Check for safety using a light stick or flashlight. Check for gas, water, or sewage breaks, check for downed electric lines and shorts. "Turn off appropriate utilities only if you suspect the lines are damaged or if you are instructed to do so."
- "If you turn the gas off, you will need a professional to turn it back on." FEMA**
3. Check for home hazards - fire dangers or dangerous spills. Be aware that spilled bleaches, gasoline and other liquids may produce deadly fumes when chemicals mix. Get advice from emergency personnel on how to clean up spilled liquids especially if there are noxious fumes.
  4. Listen to the radio for specific instructions from Public Safety agencies.  
\* Local Media will announce change in school openings and closings
  5. Wear shoes.
  6. Stay off the telephone except to report emergencies.
  7. Check on neighbors especially the elderly, disabled or those with small children
  8. After the emergency is over, let relatives know how and where you are.

# IN CASE OF . . . EARTHQUAKE:

## **BEFORE:**

Follow Emergency Basics 1-9 plus.....

1. Know the earthquake plan for your children's school. Discuss it with them.

2. Have earthquake drills

! Identify safe spots in each room

! Act out getting to the safe spot in less than 2 seconds and covering your head

! Identify danger zones to stay away from bookcases, windows, furnishings that could fall

! Drill: Once a month have a child yell "EARTHQUAKE" - Everyone should respond then discuss choices made

## **DURING:**

1. STAY CALM, REASSURE OTHERS:

expect loud noises, sounds will come from the motion of the ground, the structure of the building, and from falling objects.

2. IF INSIDE: Stay inside and find protection in a doorway, hallway, under a desk or table, away from tall book shelves, or glass.

Avoid (brick) masonry walls, chimneys fireplaces. Cover your head and face with anything handy (coat, blanket, cardboard) to shield from falling debris and splintering glass.

3. IF OUTSIDE: Stay there, move away from buildings, trees, power poles/lines. The greatest danger from falling debris is just outside doorways and close to outer walls.

4. IF DRIVING: Stop as soon as possible. Never stop on or under bridges, overpasses, under power lines or where buildings can fall on you, stay in the vehicle. A car is an excellent shock absorber, it will shake but is fairly safe. When you drive on watch for hazards created by the earthquake such as fallen objects, downed power lines, broken or undermined roads.

5. IF IN AN OFFICE BUILDING: Stay next to a pillar or support column, under a heavy table or desk, away from windows. File cabinets should not open toward you.

6. IF AT A PUBLIC EVENT: theater/ athletic stadium: drop to the floor between the seats, cover your head, hold on and ride it out. DO NOT RUSH FOR THE EXITS as hundreds of others will do. Leave calmly, avoid elevators, watch for panic in crowds.

**AFTER:** Be prepared for additional aftershocks.

1. Check for injuries - provide emergency First Aid. Do not try to move seriously injured persons.

2. Be prepared to respond to psychological needs created by the trauma of the experience. Stay with small children - they fear separation during times of stress.

3. Check for safety. Turn off appropriate utilities.

Check for gas, water, sewage breaks.

- Check for downed electric lines and shorts.

- Check for fire hazards, chemical spills, toxic fumes. If there is leaking gas, leave the house and report to authorities.

- Check building for cracks around chimney and foundation.

- Open cabinets and closets carefully and be ready for falling objects

4. Flashlights or lightsticks are safe: Do not turn on electrical switches, light matches, or create sparks until you are sure there are no gas leaks.

5. Wear shoes - clean up dangerous spills and broken glass and debris.

6. Listen to the radio for specific instructions from Public Safety agencies.

7. Stay off the telephone except to report emergencies - put phones back on the hooks.

8. Stay out of severely damaged buildings, aftershocks may finish them off.

9. Confine or leash frightened pets.

10. NEVER ASSUME DOWNED POWER LINES ARE DEAD - or you may be! People, metal and damp objects are good electrical conductors. To avoid shock and serious burns stay back. If you are in your car, and live wires have fallen across the car, remain in your car until help arrives. If trying to rescue someone in contact with live wires, use a wooden pole or other non conductive material to move the wire.

11. Do not go sightseeing.

12. Notify family to let them know how and where you are. If you must leave, leave a message of your intended route and destination and who is with you.

13. Practice strict sanitation. Keep fingers out of mouths.

## POWER OUTAGE:

### BEFORE:

Know the location of electrical fuse box and circuit breaker.

- Have antifreeze.
- Have emergency supplies (water, food, first aid, flashlight, etc.)

### DURING:

1. Unplug all major appliances. When the power comes on, the power surge could ruin appliances.
2. Report any downed power lines.
3. DO NOT OPEN the refrigerator and freezer
4. In case of long term power failure in the winter, you may need to winterize your home to protect your pipes from freezing.
  - Shut off the water at the street.
  - Drain all the water from your pipes at the lowest faucet. Flush all toilets so there is no water left in them.
  - Turn off the gas to the water heater and drain it.
  - Pour antifreeze in all drains, toilet bowls and toilet tanks.
5. Leave for a location with power or stay in your home. If you stay, it is easier to heat one room than the whole house. Remember that heating/cooking equipment requiring gasoline, propane, white gas, coalman fuel or charcoal briquets should not be used inside.

### AFTER:

1. When the power comes on, plug in appliances one by one to prevent overloading the system.
2. Turn the water back on. Be sure all taps are turned off first.
3. Check the food in the refrigerator/freezer. If the door is not opened, food in the refrigerator should stay cold up to 6 hours. Foods "*warmer than refrigeration*" temperatures more than 2 hours should be discarded. If food from the freezer is still as cold as refrigeration temperatures, it can be eaten but do not re-freeze. Meat that still has ice crystals can safely be re-frozen. If meat is thawed and "refrigeration cold", it can be cooked and eaten or re-frozen. In a well filled freezer, food will have ice crystals for about 3 days.(USU Extension)

## HIGH WINDS

### BEFORE:

1. Secure objects such as outdoor furniture, tools, trash cans, etc.
2. Have emergency supplies: water, food, first aid, etc.
3. Listen to the radio for weather updates.
4. Be prepared to board or tape up windows.
5. Open a window at the opposite end of the house about 1" to relieve pressure.

### DURING:

Take shelter in center hallways, closets or basement areas away from windows. Avoid areas where flying objects may hit you.

### AFTER:

Clean up. Windows: use duct tape and plastic to mend if cracked; plywood to board up if broken.

## SEVERE THUNDER & LIGHTNING:

### INDOORS:

Stay away from open doors, windows, fireplaces. Close the curtains to protect you from shattered glass.

Don't use electrical equipment (hair dryers, electric blankets, etc) during the storm  
Don't use the telephone except for emergency. Lightning may strike telephone lines.

### OUTDOORS:

Don't use metal objects (lawn mowers, fishing rods, golf clubs. Remove metal cleated golf shoes).  
Get out of the water and off of small boats. Avoid being the highest object in any area. **If you feel an electrical charge** (your hair stands on end or skin tingles) drop to the ground in a crouched position with hands on knees and your head between them . DO NOT lie flat on the ground.

### FIRST AID:

1. Persons struck by lightning receive a severe electrical shock and may be burned where the lightning entered and left the body, but they can be handled safely, they carry no electrical charge.
2. A person struck by lightning can often be revived by prompt mouth to mouth resuscitation, cardiac massage and prolonged artificial respiration.

## **BLIZZARDS:**

Listen to weather advisories and avoid traveling in blizzard conditions if possible.

If you are trapped in a car by a blizzard:

1. Stay in the vehicle, do not attempt to walk out; disorientation occurs quickly in blowing, drifting snow.
2. Avoid overexertion from trying to push the car out or shoveling heavy drifts.
3. Run the motor only about 10 minutes each hour for heat and only with a rear window slightly open for ventilation. Be cautious of carbon monoxide poisoning make sure the exhaust pipe does not become blocked with snow.
4. Make yourself visible: raise the hood, tie red cloth to the antenna.
5. Exercise by clapping hands, moving fingers, arms, legs to keep blood circulating. Change positions frequently.
6. Do not eat snow - it will lower your body temperature.
7. Keep watch - do not allow all occupants of the car to sleep at once.

## **FLOODS:**

### **BEFORE:**

1. Find out if your residence is in a probable flood plain. Make plans what to do, where to go.
2. Store emergency supplies: water, food, first aid, medications, documents, radio, flashlights etc.
3. Listen to the radio or TV for changing weather conditions.
4. Place sandbags, lumber, plastic sheeting etc. in strategic places. (Sandbags should be stacked away from the building far enough to avoid damaging the walls.)
5. Make sure vehicles are at least ½ full in case of evacuation.
6. Prepare for evacuation.
7. Move valuables to an upper floor or as high as possible.

### **DURING:**

1. Stay calm.
2. If there is time, disconnect all gas and electric appliances. Shut off the main water valve to keep contaminated water from entering the house. Also shut off the power at the main breaker. Remember, if you shut off the gas, a professional will have to come turn it back on.
3. If asked to evacuate, use travel routes recommended by local authorities to reach the

Evacuation Center. Drive slowly in water, use low gear. If your car stalls, abandon it as soon as possible.

4. Listen for further instructions on the emergency frequency of your radio. (KSL 1160 AM)

### **AFTER:**

1. Do not return home until local authorities say that it is safe.
2. Check your home carefully for structural damage, gas leaks and downed electrical wires.
3. Don't use electrical appliances that have been flooded until repaired.
4. Don't use food that has been contaminated by flood waters.
5. Don't drink tap water until authorities say it is safe to do so.
6. Clean everything. Flood water carries contaminants and disease. Throw out all wet food, medicines and cosmetics.

## **FIRES:**

**TAKE AWAY FUEL**

**TAKE AWAY AIR**

**TAKE AWAY HEAT**

### **PREVENTION**

1. Practice fire resistant housekeeping; discard rubbish, trash, oily rags in metal cans outside home. Use proper size fuses, replace frayed cords, don't overload electrical outlets.
2. Store flammable liquids outside the home in tightly closed metal containers.
3. Maintain smoke detectors and fire extinguishers in working order.
4. Keep garden hose near the faucet, especially in the winter when fire danger is the greatest
5. Keep oak brush, weeds, etc cut back at least 30' from the house

### **BASIC FIREFIGHTING**

1. Keep an escape route between you and the fire.
2. Point the fire retardant at the base of the fire, where the flames meet the fuel in a sweeping motion.
3. If your clothes catch on fire:

**STOP! DROP! And ROLL!!**

4. Escape: Have two ways out of every room. GET OUT FAST! Don't stop to dress, gather pets, valuables or toys. Smoke and toxic gasses rise and can kill you in minutes. Crawl on your hands and knees. Take short small breaths. Cover mouth with a cloth if possible. If a door is hot, do not open it. Keep doors and windows closed. ONCE OUT - STAY OUT!
5. Have a pre-arranged meeting place outside. When 2 people arrive one should leave to call the fire department. The 2<sup>nd</sup> stays to tell the family the 1<sup>st</sup> has gone so no one tries to go back in to find him.

### **TYPES OF FIRES**

**Electrical fires** - be sure to shut off the electricity first. Then put out the flames with an extinguisher, water or other fire retardant. **IF YOU CAN'T SHUT OFF THE ELECTRICITY, DO NOT USE WATER ON AN ELECTRICAL FIRE.**

**Oil Grease or Gasoline Fire** - Smother the flames. Use your fire extinguisher, a lid, bread board, salt, baking soda, or earth. **DO NOT USE WATER.**

**Gas Fire** - Shut off the gas supply. Use a fire extinguisher, water, sand or earth.

## **CHEMICAL:**

Hazardous Materials are chemical substances, which if released or misused, can pose a threat to our health and/or environment. This is most likely in the case of a tanker spill on the highway.

### **ON THE SCENE:**

1. If you witness a Chemical emergency, stay clear of the chemical and vapors or smoke. CALL 911.
2. If you are in a vehicle, close the windows, turn off the air systems, and leave the area.

### **NOTIFICATION:**

Orders to Evacuate or Shelter-In-Place may be given if there is a threat to the community. You may be notified by:

1. City Watch - a reverse 911 system with a pre-recorded message.
2. A knock on the door by uniformed fire or police personnel or by CERT volunteers.
3. An announcement by loud speaker from an official police or fire department vehicle.
4. The Emergency Alert System on TV or Radio.
5. Sirens at a local refinery or business.

6. Neighborhood block captain.
- IF YOUR NEIGHBORS TELL YOU THEY RECEIVED NOTIFICATION, IT PROBABLY APPLIES TO YOU TOO!**

### **EVACUATE:**

- If you are requested to evacuate, directions may be provided for safe routes to follow. Go to a designated shelter - "reception center" to check in then you may go to another safe location (home of a relative or friend, motel etc)
2. Take 72 hour kits - include all necessary medications for extended period of time.
  3. Shut off all appliances.
  4. Leash or cage pets and/or take them with you, if possible. However, most shelters will not accept pets.
  5. Lock all doors and windows. Leave a message as to where you have gone.
  6. Follow given evacuation routes.

## **SHELTER-IN-PLACE**

This is a method of protecting yourself, family and small pets from the effects of a released chemical.

1. If possible, bring pets inside.
2. Go inside, close and lock all doors and windows to the outside.
3. Turn off all heating/air conditioning systems and switch vents to the "closed" position.
4. Close all fire place dampers.
5. Go to one room and
  - Use a basement room only as a last resort. Some chemicals are heavier than air and may seep into basements.
  - Choose a room with a bathroom attached if possible.
  - Seal all windows, doors, and vents with plastic sheeting, wax paper, or other material and tape. Include spaces around pipes.
  - Place damp towels under doorways
  - Close the drapes/shades over windows and stay away from the windows.
6. Remain in place until you are told by police or fire personnel or through radio/TV broadcasts that it is safe to leave.
7. When the chemical emergency is over, open all doors and windows for ventilation.

# Other Re-Sources of Information

## Emergency Preparedness Information:

- [www.beprepared.com](http://www.beprepared.com) - (Emergency Essentials)
- [www.bt.cdc.gov](http://www.bt.cdc.gov) (CDC - Emergency Preparedness & Response)
- [www.citizencorps.gov/programs/cert.shtm](http://www.citizencorps.gov/programs/cert.shtm) (Community Em. Response)
- [www.des.ut.gov](http://www.des.ut.gov) (Utah State Division of Emergency Services & Homeland Security)
- [www.disaster-resource.com](http://www.disaster-resource.com) (Disaster Resource Guide)
- [www.fruitheightscity.com](http://www.fruitheightscity.com) (Fruit Heights City )
- [www.fema.gov](http://www.fema.gov) (Federal Emergency Management Agency )
- [www.geology.utah.gov](http://www.geology.utah.gov) (Utah Geological Survey)
- [www.hlunix.hl.state.ut.us/](http://www.hlunix.hl.state.ut.us/) (Utah Department of Health)
- [www.nws.noaa.gov](http://www.nws.noaa.gov) (National Weather Service)
- [www.neic.usgs.gov](http://www.neic.usgs.gov) (National Earthquake Information Center)
- [www.nod.org/emergency/index](http://www.nod.org/emergency/index) (National Organization on Disability >Emergency Preparedness)
- [www.providentliving.org](http://www.providentliving.org) (LDS church) - guides to food storage, preparation
- [www.ready.gov](http://www.ready.gov) (US Department of Homeland Security) much good information
- [www.redcross.org/services/disaster/](http://www.redcross.org/services/disaster/) (American Red Cross)
- [www.training.fema.gov/emiweb/CERT/](http://www.training.fema.gov/emiweb/CERT/) (CERT Training)

Check Google or other web search engines for emergency preparedness products and information. This is a partial list and is intended for information only.



## Notification For Emergency Personnel

The following colored paper should be put (taped) on the front door or the front of your house where it may be easily spotted by Emergency Services and Ward and Stake Members.

- **GREEN:** ALL IS WELL
- **YELLOW:** - WE NEED HELP BUT IT IS NOT CRITICAL
- **RED:** - WE NEED IMMEDIATE HELP
- **BLUE** - THERE IS A DECEASED PERSON HERE
- **BLACK LETTERS ON WHITE** THIS HOME IS  
VACANT - NOBODY IS HOME -- ALREADY  
EVACUATED

These sheets can be replaced by blank sheets of similar colors.

**ALL  
IS  
WELL**

**Green**

**WE NEED  
HELP  
BUT IT IS  
NOT  
CRITICAL**

Yellow

**WE  
NEED  
IMMEDIATE  
HELP**

**Red**

THERE IS A  
DECEASED  
PERSON  
HERE

**THIS HOME IS**  
**VACANT**  
**OR**  
**NOBODY IS HOME**  
**OR**  
**ALREADY**  
**EVACUATED**

We have gone to \_\_\_\_\_ Phone \_\_\_\_\_

We includes \_\_\_\_\_

White